

All about



ASCO Dry Ice Pelletizer Type A55P



In addition to dry ice pelletizers we also manufacture and supply:

- Automatic CO2 Production Plants
- CO2 Stack Gas Recovery Plants
- Dry Ice Slices/Block/Pelletizer Machines
- CO2 Gas Recovery Systems for Dry Ice Machines
- Cryogenic and CO2 Static and Transportable Tanks
- **ASCOJET** dry ice blasting systems
- CO2 Cylinder Filling Systems
- CO2 Atmospheric Vaporisers
- CO2 Detectors
- CO2 Flowmeters
- Low to Low Pressure CO2 Transfer Pumps
- CO2 Testing Equipment (Dew Point / Purity / Carbonation)
- Ancillary CO2 Equipment

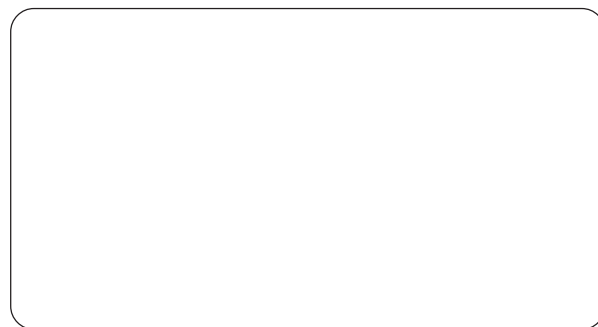

1271e

The fully automatic, hydraulically driven dry ice pelletizer A55P is a compact and powerful and versatile machine for the production of dry ice. The A55P produces pellets in four different sizes. This way it always supplies freshly produced dry ice of high quality for dry ice blasting as well as for cooling purposes.

In-house dry ice production guarantees a maximum of quality and flexibility in the daily working process. With an output capacity of 55 kg dry ice pellets per hour, the A55P provides this flexibility and quality already for a medium-sized dry ice demand. This makes this machine perfect for endusers who wish to establish their own in-house dry ice production. Gas companies will also find it very useful as it allows them, by means of smaller production centres, to cover a wider geographic area with their fresh dry ice service.

Ask us for further details and offer:

Switzerland (Head Office)
 Industriestr. 2, CH-8590 Romanshorn
 Tel. + 41 71 466 80 80 Fax + 41 71 466 80 66
 e-mail: info@ascoco2.com

ASCO CARBON DIOXIDE LTD

www.ascojet.com

New Zealand
 Box 16134, NZ-Christchurch
 Tel. + 64 3 349 7029 Fax + 64 3 349 4337
 e-mail: info@asco.co.nz

Function and Applications

The A55P dry ice pelletizer requires a liquid CO2 supply (pressure 13 - 22 bar) and power supply of 400 V / 50 Hz / 3 Ph+E (other voltages available on request). The machine features instant push button start and all functions are controlled by an inbuilt PLC. Dry ice snow is produced in the snowing chamber, pressed and then extruded by a powerful hydraulic unit. Hard, dense dry ice pellets are produced within less than one minute after push button start.

To ensure continuous, reliable operation of the pelletizer, oil temperature, cycle time, motor overload, CO2 inlet pressure and hydraulic pressure are monitored and displayed on the control panel.

Technical Specifications

Dry Ice Pelletizer A55P-D3

Production capacity:	55 kg/hr
Voltage:	400 V / 50 Hz / 3 Ph+E (other voltages on request)
Power consumption:	1.6 kW
Total dimensions incl. standard machine base (l x w x h):	1150 x 600 x 1300 mm
Dimensions pelletizer (l x w x h):	1150 x 600 x 700 mm
Weight net incl. standard machine base:	approx. 147 kg (with hydraulic oil) approx. 141 kg (without hydraulic oil)
CO2 inlet connection:	1/2" BSP female
CO2 source:	CO2 Storage Tank, liquid phase (13 - 21 bar)

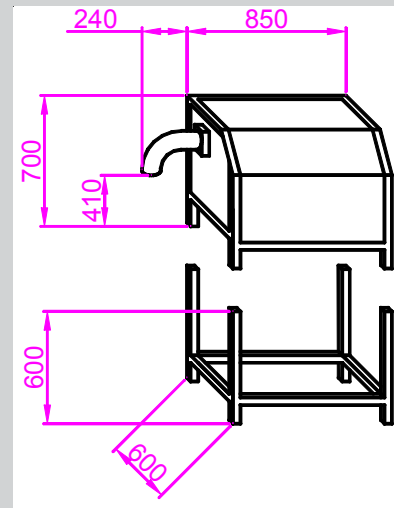

(On request, the pelletizer is also available without machine base.)

Options

The dry ice pelletizer A55P-D3 is standardly equipped with an extruder plate for the production of pellets with a diameter of 3 mm. Such pellets are used especially for dry ice blasting purposes. Optional extruder plates for pellets with a diameter of 6 mm, 10 mm and 16 mm are available. The A55P, however, can also be delivered standardly equipped with extruder plates for 6, 10 or 16 mm pellets.

Pellet size	3 mm	6 mm	10 mm	16 mm
Application	Dry ice blasting	Cooling purposes	Cooling purposes	Cooling purposes

Automatic Dry Ice Filling System

As the machine is fully automatic, start/stop can be achieved by simply pressing a button. With the addition of an optional control system, this unit can be set to automatically fill all kinds of blasting machines or storage containers.



Automatic filling of a storage container respectively of a dry ice blasting machine

The optional automatic filling system, with the appropriate control system, allows a preset low dry ice level to automatically start the dry ice pelletizer, with automatic stop at the preset high level. For industries like tyre/rubber manufacturers, producers of PU-parts, foundries etc. who need to clean moulds, a stationary dry ice blasting system is often required, and this higher level of automation is ideal.

The automatic fill control system can also be added at a later stage to the A55P pelletizer if required.

As a further option a higher machine base for the filling of an **ASCOJET 2001RS** or **ASCOJET 2001CS** is available.

Versions and Options

1. Automatic dry ice filling system with a platform of 600 x 800 mm which is suitable for all **ASCOJET** and similar sized blasting units or smaller storage containers
2. Automatic dry ice filling system with a platform of 1000 x 1000 mm which is for all larger blasting machines and storage containers
 - A. Standard machine base for the automatic filling of dry ice containers or of an **ASCOJET 1502**; increases the total height by 600 mm.
 - B. Higher machine base for the automatic filling of an **ASCOJET 2001RS** or **ASCOJET 2001CS**; increases the total height by 800 mm.